

L-864



L-865 / L-864



L-810



L-810

LED Based Obstruction Lights
LED Lighting Brochure
for Obstruction Applications



Certified to:

FAA AC NO: 150/5345-43F
FAA Engineering Brief No. 67

Compliant to:

ICAO Annex 14, 4th Edition, July 2004
ICAO Aerodromes Design Manual, Chapter 18
Canadian Aviation Regulation CAR 621.19
(Transport Canada)
DGAC Mexico

Qualified By:

Intertek ETL

US Patent #7,281,821
other patents pending

LED Based L-864/L-865 Flashing Dual (White/Red) Strobe

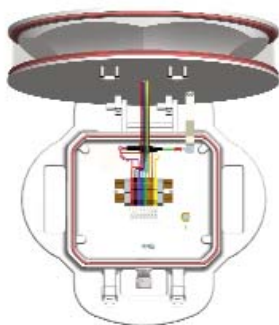
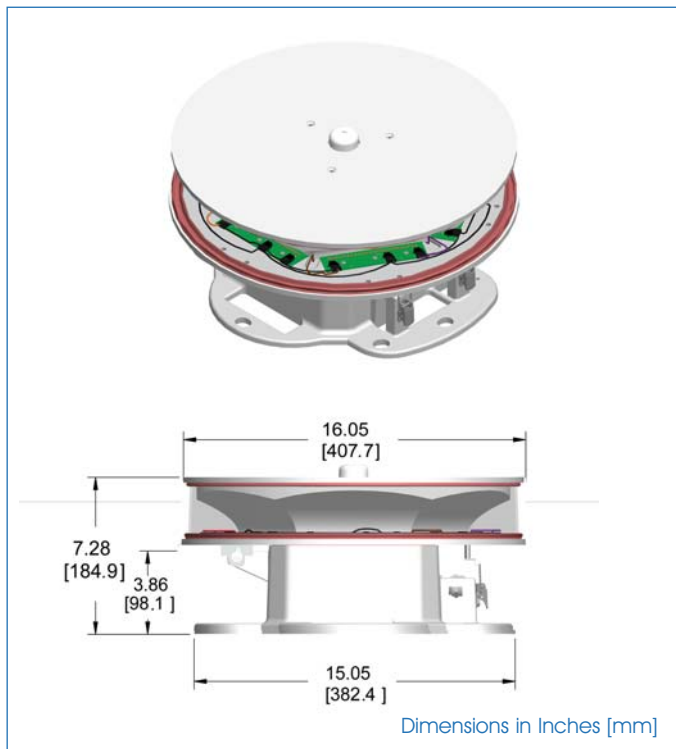

Flip top design for simple installation

Application:

The all LED Dialight Medium Intensity White Strobe and Red Beacon is designed for the lighting of communication towers, smoke stacks wind generators and other obstructions to aerial navigation, as specified by the FAA and FCC. The Dual L864 / L865 uses LED technology for light output from both the Red Beacon and White Strobe. Unlike conventional Xenon flashtube technology, little or no maintenance is required during its lifetime. Working voltages of less than 200VDC are significantly less than those of Xenon flashtube designs; therefore, this system represents an advance in safety. The Dialight Dual L864 / L865 LED beacon operates from a 48VDC supply. The power supply / control box can be located up to 550 ft away from the light engine, such as at the base of the tower.

Order code:

D1RW-C13-008	48VDC FAA OEM
D1RW-C13-008-EU	100-240VAC, European Version

Flashhead Weight: 26 lbs

Operating Voltage: Universal 100/240 VAC 50/60Hz power factor corrected supply

Candela:	White Day	20,000 cd
	White Night	2,000 cd
	Red Night	2,000 cd

Wattage:	White Day	90W
	White Night	35W
	Red Night	25W

Power Factor: >0.9

Operating Temp: -40°F to +131°F (-40°C to +55°C)

Synchronization: Multiple unit sync from single controller
(Operates with other manufacturers of GPS sync devices)

LED Based L-864/L-865 Flashing Dual (White/Red) Strobe

FEATURES	BENEFITS
Industry's Longest Warranty	- Complete performance 5 year warranty (Xenon technology only 2 years)
All LED Flash Head = 10+ Years Life Expectancy	- Long life and resistant to shock and vibration Resistant to shock and vibration Reduction in expensive tower climbs and maintenance costs / unplanned site visits
No More Dangerous High Voltage Power Supply Required	- Enables the use of low voltage flexible cable - Eliminates the need to send high voltage up a tower - Provides considerable safety advantages - Uses standard low voltage supply - Eliminates corrosion due to ozone effects
Designed to Withstand IEC61000-4-5, 6kV/3000A, 1.2/50s, 8/20s, 2 ohm Output Impedance, Combination Wave, Line-Line and Line-Ground	- Provides excellent protection against lightning and surges
Smallest Flash Head in the Industry, 7.28" High	- Significantly less wind loading than Xenon dual strobes
Very Precise Optics (Patented)	- Minimum ground scatter light - Community friendly lighting system
Uses State-of-the-Art High Flux LED Technology	- Replaces high maintenance Xenon tubes - Resistant to shock and vibration (no fragile Xenon tubes)
LED's Produce No Radio Frequency Blast	- Eliminates RF interference with cell networks associated with Xenon technology
IP66	- Completely sealed from the outside environment
Lightest Flash Head in the Industry - 26lbs	- Easy to Handle and Install



2007



2008

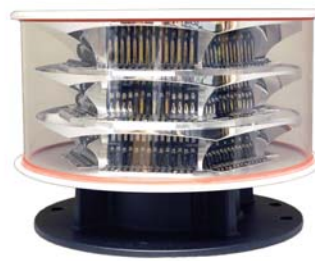

2009



2010



Certified to:

FAA AC NO: 150/5345-43F
 FAA Engineering Brief No. 67

Qualified By:
 Intertek ETL

Compliant to:

ICAO Annex 14, 5th Edition, 2009
 ICAO Aerodromes Design Manual, Chapter 18
 Canadian Aviation Regulation CAR 621.19
 (Transport Canada)
 DGAC Mexico

US Patent # 7,281,821
 Other Patents Pending

LED Based L-864 Red Medium Intensity Beacon

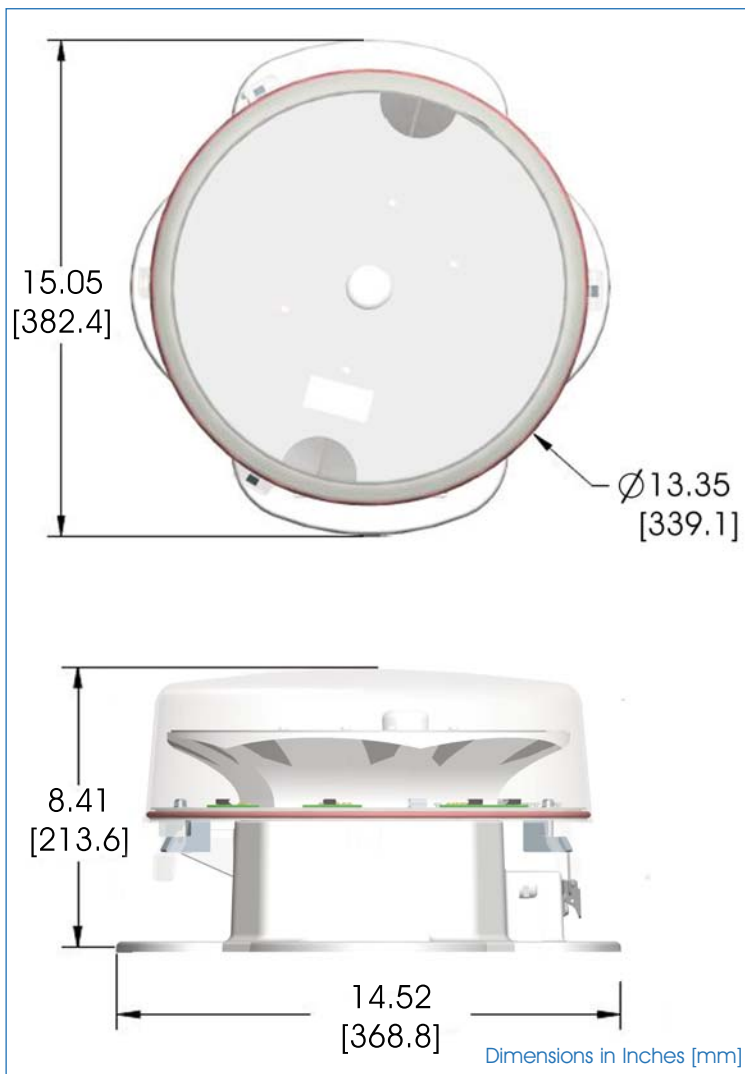

Application:

The Dialight D464 Series LED based medium intensity red beacon utilizes state-of-the-art optical design to achieve the most compact, efficient, FAA compliant L864 device in the market. While it readily interfaces into existing installations, its robust, low power design will provide years of maintenance free service.

Order codes:

D464-A13-001	120 / 240 VAC FAA
D464-A13-001EU	120 / 240 VAC ICAO
D2643002	Retrofit Adapter

Unit Weight:

20lbs (9Kg)

Supply Voltage:

120-240 VAC Universal Input

Watts:

20W Rated (10 Watts EQ)

Operating Temp:

-40°F to +131°F (-40°C to +55°C)

Power Factor:

>0.9

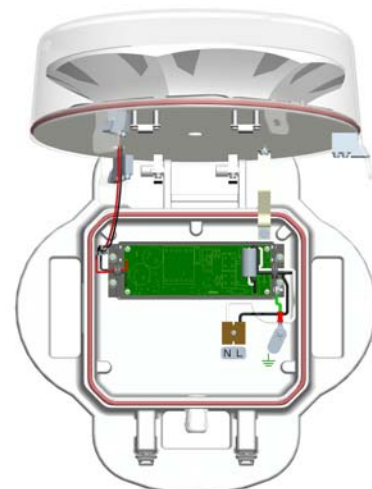

Flip top design for simple installation

LED Based L-864 Red Medium Intensity Beacon

FEATURES	BENEFITS
Industry's Longest Warranty	- Complete performance 5 year warranty (Xenon technology only 2 years)
All LED Flash Head = 10+ Years Life Expectancy	- Long life and resistant to shock and vibration Reduction in expensive tower climbs and maintenance costs / unplanned site visits
Uses State-of-the-Art High Flux LED Technology	- Replaces high maintenance, fragile incandescent bulbs and xenon tubes
Environmentally Friendly (20 Watt Power Consumption)	- Lowest power consumption L864 on the market Over 90% more efficient than incandescent
Very Precise Optics (Patented)	- Minimum ground scatter light Community friendly lighting system
Smallest Flash Head in the Industry, 8.41" high	- Significantly less wind loading than a xenon or incandescent
New Hinged Lid Design	- Easy access to terminal block wiring
IP66	- Completely sealed from the outside environment
Lightest Flash Head in the Industry - 20LBS	- Easy to handle and install

Dialight's LED Technology Innovations Over the Years



2000



2004

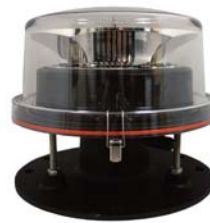

2006



2010





Meets:

FAA AC NO: 150/5345-43F
 FAA Engineering Brief No. 67
 ICAO Annex 14, 4th Edition, July 2004
 ICAO Aerodromes Design Manual, Chapter 18
 Canadian Aviation Regulation CAR 621.9
 Nachrichten für Luffahrer Teil I Langen, 6. Januar 2005
 German Air Traffic Control Notices For Pilots Part I 6, January 2005

Qualified By:

Intertek ETL
 Lighting Sciences Canada

Patents Pending

L-810 860 Series Red LED Obstruction Lights

Order codes:

860-1R01-001	Single Fixture, FAA, 120 VAC
860-1R03-001	Single Fixture, FAA, 12 VDC
860-1R04-001	Single Fixture, FAA, 48 VDC
860-1R05-001	Single Fixture, FAA, 24 VDC
860-1R02-001	Single Fixture, 230 VAC
860-3R03-001	Single Fixture, Low Wattage, 12 VDC
860-5R02-001	Single Fixture, ICAO, 230 VAC, 10 cd
860-1R02-001-EU	Single Fixture, European Ver, 230 VAC
860-4R02-001-EU	Single Fixture, European Ver, 230 VAC, 50cd
860-1R01-002	Dual Fixture, FAA, 120 VAC
860-1R03-002	Dual Fixture, FAA, 12 VDC
860-1R04-002	Dual Fixture, FAA, 48 VDC
860-1R05-002	Dual Fixture, FAA, 24 VDC
860-1R02-002	Dual Fixture, 230 VAC
860-3R03-002	Dual Fixture, Low Wattage, 12 VDC
860-5R02-002	Dual Fixture, ICAO, 230 VAC, 10 cd
860-6R01-002	Dual Fixture, TC, 120 VAC
860-7R02-002	Dual Fixture, CASA, 230 VAC, 100 cd
860-1R02-002-EU	Dual Fixture, European Ver, 230 VAC
860-4R02-002-EU	Dual Fixture, European Ver, 230 VAC, 50cd

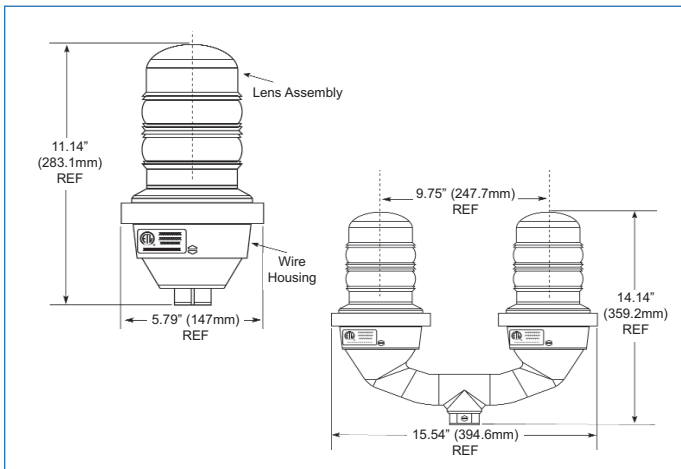

Dimensions in Inches [mm]

Features & Benefits:

- ▷ Available as a single or dual unit
- ▷ Available in 12VDC, 24VDC, 48VDC, 120VAC, and 220VAC versions (50 or 60HZ)
- ▷ Earth grounding provisions provided
- ▷ Unique optically designed lens to enhance LED operation and provide 360° visibility
- ▷ State-of-the-art high-flux LED technology
- ▷ Lasts years longer than an incandescent
- ▷ Weather/corrosion resistant lamp assembly and housing
- ▷ Self-contained wiring compartment eliminates additional boxes
- ▷ Threaded 1" and 3/4" bottom hub for mounting
- ▷ Can be operated steady or flashed (controller not supplied)
- ▷ 5 year warranty
- ▷ Resistant to shock and vibration
- ▷ IP 65 / IP 66 / NEMA 4X rated

Application:

The Dialight 860 series is the FAA type L810 red LED obstruction light. Designed for steady burning, this fixture is used to mark any obstacle that may present hazards to aircraft navigation. The US patent office has issued patent number 6,425,678 B1 for this series.

Container Dimensions: 16.0" x 9.0" x 8.0" (Single Unit)
 406mm x 229mm x 203mm

22.0" x 17.0" x 9.0" (Dual Unit)
 559mm x 432mm x 229mm

Container Weight: 7.14lbs (Single Unit)
 16.06lbs (Dual Unit)

Supply voltage ranges: Nominal +/- 10%

Watts (Typ):

- 15 / 120mA (120 VAC Units)
- 16 / 120mA (230 VAC Units - 60 Hz)
- 16 / - (230 VAC Units - 50 Hz)
- 24 / 2.0A (12 VDC Units - Standard)
- 8 / .62A (12 VDC Units - Low wattage)
- 20 / 920mA (24 VDC Units)
- 13 / 2175mA (48 VDC Units)

Power Factor: .2 (FAA - 120 VAC Units)
 .17 (FAA - 230 VAC Units - 60 Hz)

Operating Temp: -67°F to +131°F (-55°C to +55°C)

Meets:

FAA AC NO: 150/5345-43F
 FAA Engineering Brief No. 67
 ICAO Annex 14, 4th Edition, July 2004
 ICAO Aerodromes Design Manual, Chapter 18
 Canadian Aviation Regulation CAR 621.9
 Nachrichten für Luffahrer Teil I Langen, 6. Januar 2005
 German Air Traffic Control Notices For Pilots Part I 6, January 2005



Qualified By:

Intertek ETL
 Lighting Sciences Canada
 DGAC Mexico

Patents Pending

L-810 RTO Series Red LED Obstruction Lights

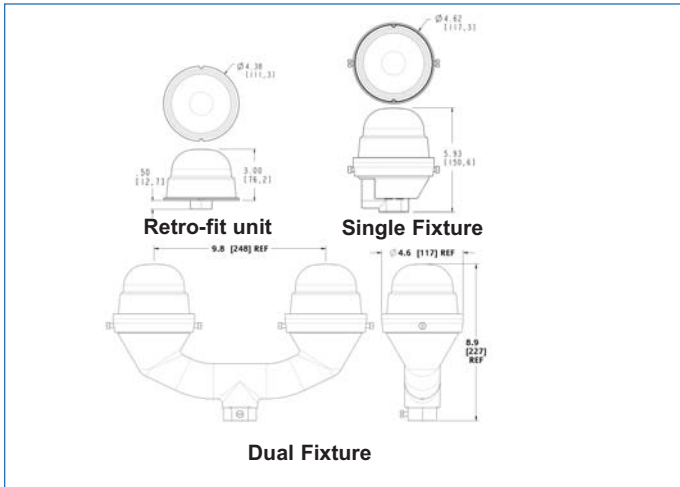

Dimensions in Inches [mm]

Features & Benefits:

- ▷ Available as a single, dual or retro-fit unit
- ▷ Available in 120 - 277 VAC and 12 - 48 VDC
- ▷ Grounding terminals provided
- ▷ Unique optical design (patent pending)
- ▷ Advanced high-flux LED technology
- ▷ Lasts years longer than an incandescent
- ▷ Weather/corrosion resistant lamp assembly and housing
- ▷ Self-contained wiring compartment eliminates additional boxes
- ▷ Threaded 1" and 3/4" bottom hub for mounting
- ▷ Can be operated steady or flashed
- ▷ Uses 95% less energy than incandescent
- ▷ 5 year warranty
- ▷ Resistant to shock and vibration
- ▷ IP65 / IP66 / NEMA 4X

Application:

The Dialight RTO Series obstruction light utilizes a unique optical, electrical and mechanical design. The RTO series is the most universal, compact and efficient obstruction light in the world. ETL Certified to the FAA requirements, the RTO series fixture is also ICAO and Transport Canada compliant. Also available as a single fixture for direct replacement of incandescent lamp/lens technology.

Order codes:

RTO-1R07-001	Single Fixture, FAA, 120-230 VAC
RTO-6R07-001	Single Fixture, TC, 120-230 VAC
RTO-1R06-001	Single Fixture, FAA, 277 VAC
RTO-1R08-001	Single Fixture, FAA, 12-48 VDC
RTO-1R07-001-EU	Single Fixture, European Ver, 120-230 VAC
RTO-1R07-002	Dual Fixture, FAA, 120-230 VAC
RTO-6R07-002	Dual Fixture, TC, 120-230 VAC
RTO-1R06-002	Dual Fixture, FAA, 277 VAC
RTO-1R08-002	Dual Fixture, FAA, 12-48 VDC
RTO-1R07-002-EU	Dual Fixture, European Ver, 120-230 VAC
RTO-1R07-004	Single Retro-Fit Fixture, FAA, 120-230 VAC
RTO-6R07-004	Single Retro-Fit Fixture, TC, 120-230 VAC
RTO-1R06-004	Single Retro-Fit Fixture, FAA, 277 VAC
RTO-1R08-004	Single Retro-Fit Fixture, FAA, 12-48 VDC
RTO-1R07-004-EU	Single Retro-Fit Fixture, European Ver, 120-230 VAC

Container Dimensions: 7.60" x 5.25" x 5.75" (Retro Unit)
 193mm x 133mm x 146mm

7.60" x 5.25" x 5.75" (Single Unit)
 193mm x 133mm x 146mm

18.6" x 12.5" x 6.40" (Dual Unit)
 472mm x 318mm x 163mm

Container Weight: 1.25lbs (Retro Unit)
 2.00lbs (Single Unit)
 4.60lbs (Dual Unit)

Supply Voltage Ranges: Nominal +/- 10%

Nominal Input Power: 6.5 (FAA - 120/230 VAC Units)
 8.5 (TC - 120/230 VAC Units)
 8.0 (FAA - 277VAC Units)
 3.5 (FAA - 12-48 VDC Units)

Power Factor: >0.9 (All AC units)

Operating Temp: -40°F to +131°F (-40°C to +55°C)

L-810 RTO Retro-Fit Series Red LED Obstruction Lights

RETRO INSTALLATION STEPS:

- ▶ Remove existing lens and clamp 6 from existing fixture
- ▶ Do not discard clamp 6 since it will be used to secure light assembly 1A .
- ▶ Remove and discard all internal components required for use with incandescent bulb
- ▶ Leave only the source wires that lead into the existing base 2C .
- ▶ Electrically connect the supply wires to the light assembly 1A wires
 - same as SINGLE FIXTURE installation
- ▶ Tuck the connected wires inside the existing base 2C .
- ▶ Place light assembly 1A on existing base 2C and secure using existing clamp 6 .
- ▶ Restore power and verify operation

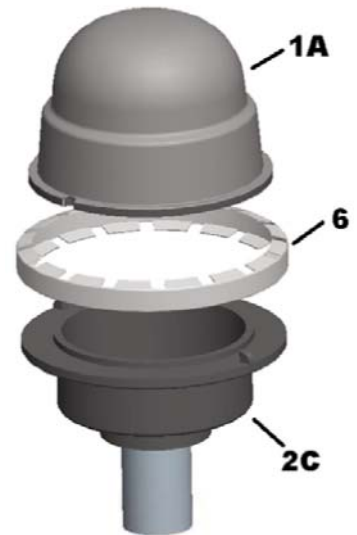

RETRO ONTO 3/4-14 NPT CONDUIT INSTALLATION STEPS:

- ▶ Electrically connect the supply wires to the light assembly 1A wires
 - same as SINGLE FIXTURE installation
- ▶ Use a 1-1/4" wrench to tighten and attach the light assembly 1A to the conduit
- ▶ Restore power and verify operation
Please refer to product data sheet for electrical parameters if required

RTO-1R07-004	Single Retro-Fit Fixture FAA, 120-230 VAC	<p>Installation of RTO retro-fit version</p>
RTO-6R07-004	Single Retro-Fit Fixture TC, 120-230 VAC	
RTO-1R06-00	Single Retro-Fit Fixture FAA, 277 VAC	
RTO-1R08-004	Single Retro-Fit Fixture FAA, 12-48 VDC	
RTO-1R07-004-EU	Single Retro-Fit Fixture, European Ver, 120-230 VAC	

Dialight reserves the right to make changes at any time in order to supply the best product possible.

The most current version of this document will always be available at:

http://www.dialight.com/Assets/Brochures_And_Catalogs/Signaling/Obstruction_Brochure.pdf

Obstruction_Brochure_C